

## NPN Transistors

### ■ Features

- Excellent  $h_{FE}$  linearity and high  $h_{FE}$

$h_{FE} = 60$  to  $400$  ( $V_{CE} = 2\text{ V}$ ,  $I_C = 1\text{ A}$ )

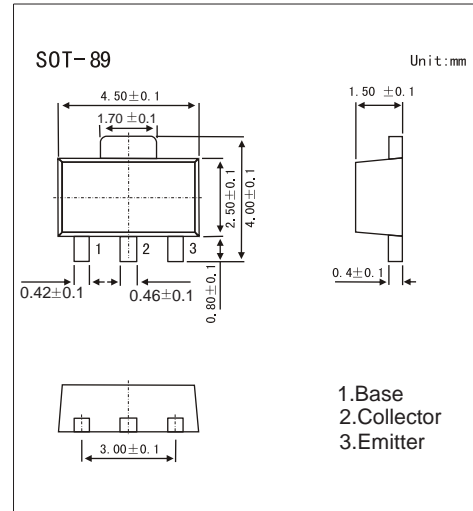

### ■ Absolute Maximum Ratings $T_a = 25^\circ\text{C}$

Parameter	Symbol	Rating	Unit
Collector to Base Voltage	$V_{CBO}$	40	V
Collector to Emitter Voltage	$V_{CEO}$	30	V
Emitter to Base Voltage	$V_{EBO}$	6	V
Collector Current to Continuous	$I_C$	3	A
Collector Dissipation	$P_c$	0.5	W
Junction Temperature	$T_J$	150	$^\circ\text{C}$
Storage Temperature	$T_{stg}$	-55 to 150	$^\circ\text{C}$

### ■ Electrical Characteristics $T_a = 25^\circ\text{C}$

Parameter	Symbol	Testconditions	Min	Typ	Max	Unit
Collector-base breakdown voltage	$V_{CBO}$	$I_C=100\mu\text{A}$ , $I_E=0$	40			V
Collector-emitter breakdown voltage	$V_{CEO}$	$I_C=10\text{ mA}$ , $I_B=0$	30			V
Emitter-base breakdown voltage	$V_{EBO}$	$I_E=100\text{ uA}$ , $I_C=0$	6			V
Collector cut-off current	$I_{CBO}$	$V_{CB}=40\text{ V}$ , $I_E=0$			1	$\mu\text{A}$
Collector cut-off current	$I_{CEO}$	$V_{CE}=30\text{ V}$ , $I_B=0$			10	$\mu\text{A}$
Emitter cut-off current	$I_{EBO}$	$V_{EB}=6\text{ V}$ , $I_C=0$			1	$\mu\text{A}$
DC current gain	$h_{FE}$	$V_{CE}=2\text{ V}$ , $I_C=1\text{ A}$	60		400	
		$V_{CE}=2\text{ V}$ , $I_C=100\text{ mA}$	32			
Collector-emitter saturation voltage	$V_{CE(sat)}$	$I_C=2\text{ A}$ , $I_B=0.2\text{ A}$			0.5	V
Base-emitter saturation voltage	$V_{BE(sat)}$	$I_C=2\text{ A}$ , $I_B=0.2\text{ A}$			1.5	V
Transition frequency	$f_T$	$V_{CE}=5\text{ V}$ , $I_C=0.1\text{ mA}$ , $f=10\text{ MHz}$	50			MHz

### ■ Classification of $h_{FE}(1)$

Type	D882-R	D882-Q	D882-P	D882
Range	60-120	100-200	160-320	200-400
Marking	D882			

# NPN Transistors

## ■ Typical Characteristics

